

A FLASH MCU SOLUTION

MC9S12E128/E64

16-bit Microcontroller

TARGET APPLICATIONS

- Power Management Applications
- Industrial Controls
- Commercial Controls

The HCS12 Family of microcontrollers is the next generation of the highly successful 68HC12 architecture. Utilizing Motorola's industry-leading 0.25 μ Flash, the E128 is part of a pin-compatible family that is planned to scale from 32 Kbytes to 512 Kbytes of Flash memory. The E128 provides an upward migration path from Motorola's 68HC08, 68HC11 and 68HC12 architectures for applications that need larger memory, more peripherals and higher performance.



FEATURES

BENEFITS

HIGH-PERFORMANCE 16-BIT HCS12 CPU CORE

- 25 MHz bus operation at 3.3 V–5 V for 40 nsec minimum instruction cycle time
- Opcode compatible with the 68HC11 and 68HC12
- C optimized architecture produces extremely compact code

ON-CHIP DEBUG INTERFACE

- Single-wire background debug mode
- On-chip trace buffer with nine flexible trigger modes and multiple hardware breakpoints
- Non-intrusive emulation
- Real-time emulation of MCU functions at full operating voltage and frequency range with no limitations like traditional emulators
- Bus state analysis without the expense of a traditional emulator
- Non-intrusive debugging through a single, dedicated pin helps eliminate the need and cost of cumbersome emulator cables
- View and change internal registers and memory while running application

INTEGRATED THIRD-GENERATION FLASH MEMORY

- In-application re-programmable
- Self-timed, fast programming
 - Fast Flash Page Erase—20 msec (1024 bytes)
 - Can program 16 bits in 20 μ sec while in burst mode
- 3.3 V Flash program/erase/read
- Flash Granularity—1024 byte Flash erase / 2 byte Flash program
- Flexible protection and security
- Flexibility to change code in the field
- Efficient end-of-line programming
- Total program time for 128 Kbyte code is less than 5 sec
- Reduces production programming cost through ultra-fast programming
- No external high voltage or charge pump required
- Virtual EEPROM implementation, Flash array usable for EE extension

10-BIT ANALOG-TO-DIGITAL CONVERTER

- One 16-channel A/D converter
- 7 μ sec, 10-bit single conversion time, scan mode available
- Fast, easy conversion from analog inputs like temperature, pressure and fluid levels to digital values for CPU processing

DIGITAL-TO-ANALOG CONVERTER

- Two 8-bit digital-to-analog converters (DAC)
- 8-bit resolution
- Provides digital control capabilities of external analog devices

CLOCK GENERATION MODULE WITH PLL

- Clock monitor with self clock mode in case of no external clock
- Programmable clock frequency with 1024 options ranging from divide by 16 to multiply by 64 from base oscillator
- Real-time interrupt
- Watchdog
- Reliable, robust operation
- Provides high performance using low-cost reference crystals
- Reduces generated noise
- Reduces power consumption
- Easily able to implement real-time clock

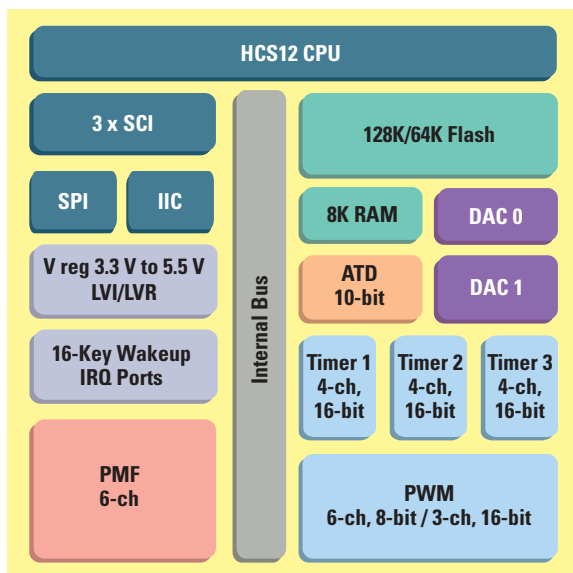

A FLASH MCU SOLUTION

MC9S12E128/E64

DATA SHEETS

S12ATD10B16CV2/D	Analog to Digital: 10-bit, 16 Channel
S12BDMV4/D	Background Debug Module
S12CPUV2/D	Central Processor Unit
S12CRGV4/D	Clock and Reset Generator
S12DAC8B1CV1/D	Digital-to-Analog Converter: 8-bit
S12DBGV1/D	Debug Module
S12FTS128KV1/D	128 Kbyte Flash EEPROM
S1211CV2/D	Inter IC Bus
S12INTV1/D	Interrupt
S12MEBIV3/D	Multiplexed Expanded Bus Interface
S12MMCV4/D	Module Mapping Control
S12OSCV2/D	Oscillator
S12PIM9E128V1/D	Port Integration Module
S12PWM8B6CV1/D	Pulse Width Modulator: 8-bit, 6 Channel
S12PMF15B6CV1/D	Pulse Modulator with Fault Protection: 15-bit, 6 Channel
S12SCIV3/D	Serial Communications Interface
S12SPIV2/D	Serial Peripheral Interface
S12TIM16B4CV1/D	Timer: 16-bit, 4 Channel
S12VREG3V3V1/D	Voltage Regulator

DEVELOPMENT TOOLS

M68MULTILINK12	Universal HC12 / HCS12 in-circuit emulator, debugger and Flash programming through BDM interface
USBMULTILINK12	USB version of M68MULTILINK12

APPLICATION NOTES

AN2287/D	HCS12 External Bus Design
AN2304/D	Implementation of a UDP/IP Stack on HCS12 Microcontrollers
AN2318/D	Using the I ² C Bus with HCS12 Microcontrollers
AN2408/D	Examples of HCS12 External Bus Design: A Companion Note to AN2287/D
AN2428/D	An Overview of the HCS12 ATD Module
AN2429/D	Interfacing to the HCS12 ATD Module
AN2438/D	ADC Definitions and Specifications

FEATURES

BENEFITS

THREE FOUR-CHANNEL TIMERS

- Three four-channel 16-bit timers with each channel programmable for input capture or output compare
- Three 16-bit pulse accumulators with event counting or gated time accumulation modes
- Flexible, programmable timer system

TWO PULSE WIDTH MODULATORS

- Six-channel, 8-bit or three-channel, 16-bit PWM with fault protection
 - Edge- or center-aligned PWM operation
 - Fault protection input
- Six-channel pulse width modulator with fault protection (PMF)
 - Three independent 15-bit counters with synchronous mode
 - Complementary channel operation
 - Programmable dead time insertion
 - Integral reload rates from 1 to 16
 - Four fault protection shut-down input pins
 - Three current sense input pins
- Efficiently implement motor control, battery charging or digital-to-analog functions
- Capable of controlling most motor types: AC induction motors (ACIM), both brushless (BLDC) and brush DC motors (BDC), switched (SRM) and variable reluctance motors (VRM), and stepper motors.

THREE SERIAL COMMUNICATIONS INTERFACES WITH IrDa

- 8192 prescaler option
- Asynchronous communication between the MCU and a terminal, computer or a network of microcontrollers
- IrDa enabled
- Exact baud rate matching
- Infrared communications capabilities

ONE SERIAL PERIPHERAL INTERFACE

- Up to 6.25 Mbps
- High-speed synchronous communication between multiple MCUs or between MCU and serial peripherals

INTER IC BUS (I²C)

- 256 clock rate options
- Provides a simple, efficient method of data exchange between devices
- Minimizes the need for large numbers of connections between devices and eliminates the need for an address decoder

UP TO 90 INPUT/OUTPUT (I/O) LINES

- Programmable pull-ups / pull-downs
- Dual drive capability
- Reduce system cost
- Able to tailor application for minimum EMC or high current loads

PACKAGE OPTIONS

PART NUMBER	PACKAGE	TEMPERATURE RANGE
MC9S12E128CPV	112 LQFP	-40 to 85°C
MC9S12E64CPV	112 LQFP	-40 to 85°C
MC9S12E128CFU	80 QFP	-40 to 85°C
MC9S12E64CFU	80 QFP	-40 to 85°C
MC9S12E128MPV	112 LQFP	-40 to 125°C
MC9S12E64MPV	112 LQFP	-40 to 125°C
MC9S12E128MFU	80 QFP	-40 to 125°C
MC9S12E64MFU	80 QFP	-40 to 125°C

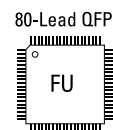
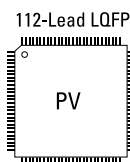

MOTOROLA

Motorola and the stylized M Logo are registered in the U.S. Patent and Trademark Office. This product incorporates SuperFlash® technology licensed from SST. All other product or service names are the property of their respective owners. © Motorola, Inc. 2003

MC9S12E128FS/D
REV 0