

# Adapt11ET24FX™ 68HC11 with 10 Base-T

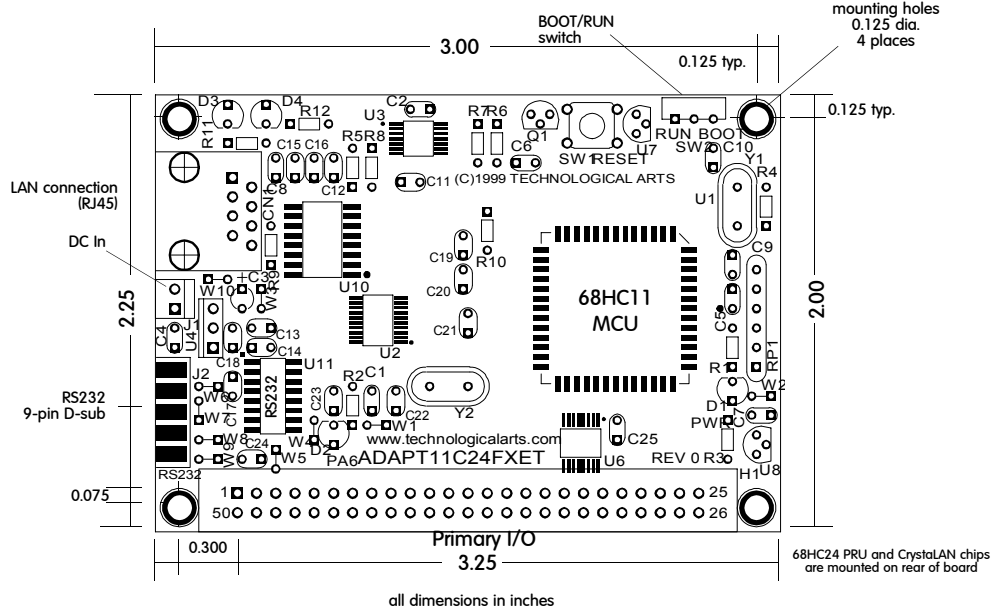

## H1 Connector Pinout

H1			
PIN	SIGNAL NAME	PIN	SIGNAL NAME
1	PD2/MISO	50	GROUND
2	PD3/MOSI	49	GROUND
3	PD4/SCK	48	PD0/RXD
4	PD5/SS*	47	+5VDC
5	PD1/TXD0	46	IRQ*
6	PA7/OC7/PAI	45	XIRQ*
7	PA6/OC6	44	RESET*
8	PA5/OC5	43	RESERVED
9	PA4/OC4	42	PC7
10	PA3/OC3	41	PC6
11	PA2/OC2	40	PC5
12	PA1/OC1	39	PC4
13	PA0/OC0	38	PC3
14	PB7	37	PC2
15	PB6	36	PC1
16	PB5	35	PC0
17	PB4	34	STRB
18	PB3	33	E
19	PB2	32	STRA
20	PB1	31	VRL
21	PB0	30	VRH
22	PE0/AN0	29	PE4/AN4
23	PE1/AN1	28	PE5/AN5
24	PE2/AN2	27	PE6/AN6
25	PE3/AN3	26	PE7/AN7

## Functional Block Diagram

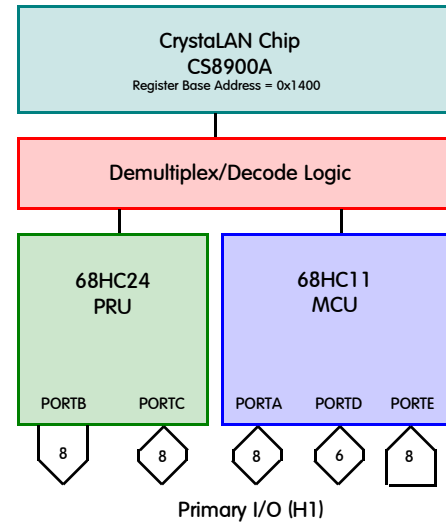

NOTE: \* indicates active low signal

## Standard Connector Options

